

ONE TIME EXIT SCHEME

USN

--	--	--	--	--	--	--	--	--	--

10EE71

Seventh Semester B.E. Degree Examination, April 2018 Computer Techniques in Power System Analysis

Time: 3 hrs.

Max. Marks: 100

**Note: 1. Answer FIVE full questions, selecting at least TWO questions from each part.
2. Assume suitable data if required.**

PART - A

- 1 a. The bus incidence matrix for the power system network is given below. Construct the oriented graph and also obtain the one line diagram the system indicating the generator positions. (04 Marks)

$$A = \begin{matrix} & e^{n-1} & \textcircled{1} & \textcircled{2} & \textcircled{3} & \textcircled{4} \\ \begin{matrix} 1 \\ 2 \\ 3 \\ 4 \\ 5 \\ 6 \\ 7 \\ 8 \end{matrix} & \begin{bmatrix} 1 & 0 & 0 & 0 \\ 0 & 0 & 1 & 0 \\ 0 & 0 & 0 & 1 \\ 1 & -1 & 0 & 0 \\ 0 & 1 & -1 & 0 \\ 0 & 0 & -1 & 1 \\ 0 & 1 & 0 & -1 \\ 1 & 0 & 0 & -1 \end{bmatrix} \end{matrix}$$

- b. What is primitive network? Give primitive element representations in impedance and admittance forms. (04 Marks)
- c. For the power system shown in Fig Q1(c), obtain A, B, C, K matrices choosing node ⑤ as reference and elements 1, 2, 3 as twigs. Hence verify i) $A_b K^t = U$ ii) $B_b = A_b K^t$

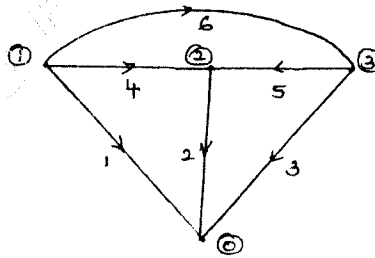

Fig Q1(c) (12 Marks)

- 2 a. Deduce the expression for Y_{BUS} by singular transformation using the concept of power invariance. (06 Marks)
- b. For the network graph shown in Fig Q2(b), determine Y_{BUS} with node 4 as reference, using singular transformation method. Self impedance of elements are marked on the figure.

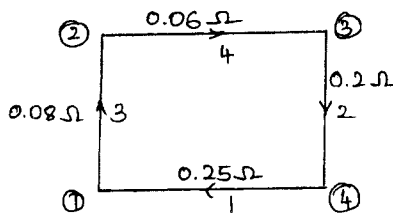
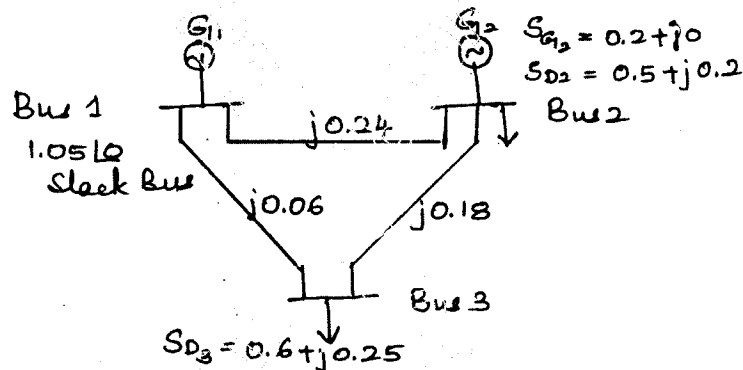

Fig Q2(b) (06 Marks)

Important Note : 1. On completing your answers, compulsorily draw diagonal cross lines on the remaining blank pages.
2. Any re-examination of identification number by evaluator and its correction is not allowed.

- c. Derive an expression for diagonal element Z_{qq} of bus impedance matrix using building algorithm when branch is added to the partial network with a neat representation of partial network. (08 Marks)

- 3 a. Write a note on :
 i) Classification of Buses
 ii) Comparison of load flow methods. (10 Marks)
- b. Using G-S load flow method, obtain the bus voltages at bus 2 and bus 3 of the system shown in Fig Q3(b) at the end of first iteration. Also calculate these voltages if the acceleration factor $\alpha = 1.6$. (10 Marks)



- 4 a. Write an algorithm for NR method in polar coordinates along with a neat flow chart. (12 Marks)
- b. Listing out the important assumptions involved, explain the fast Decoupled load flow method. (08 Marks)

PART - B

- 5 a. Derive an expression for co-ordination equation used for economic generation scheduling neglecting losses and generator limits. (06 Marks)
- b. The fuel inputs per hour of plants 1 and 2 are given as
 $F_1 = 0.2P_1^2 + 40P_1 + 120$ Rs/hr
 $F_2 = 0.25P_2^2 + 30P_2 + 150$ Rs/hr
 Determine the economic operating schedule and the corresponding cost of generation if the maximum and minimum loading in each unit is 100MW and 25MW, the demand is 180MW and transmission losses are neglected. If the load is equally shared by both the units determine the saving obtained by loading the units as per equal incremental production cost. (10 Marks)
- c. Discuss in brief on performance curves of thermal power plant. (04 Marks)

- 6 a. Derive expression for loss co-efficient and transmission loss in terms of generation in an interconnected system. (08 Marks)
- b. Compute the loss co-efficient for the network shown in Fig Q6(b). Use the following given data.

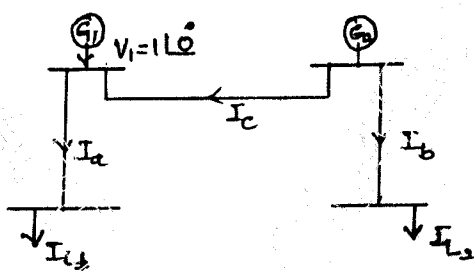

Fig. Q6(b)

$$I_a = 1.0 - j 0.15 \quad ; \quad Z_a = 0.02 + j0.15 \text{ pu}$$

$$I_b = 0.5 - j 0.1 \quad ; \quad Z_b = 0.03 + j 0.15 \text{ pu}$$

$$I_c = 0.2 - j 0.05 \quad ; \quad Z_c = 0.02 + j 0.25 \text{ pu}$$

(12 Marks)

- 7 a. Write the necessary equations, explain the solution of swing equation by point by point method. Mention the assumptions made. (10 Marks)
- b. Illustrate clearly the steps involved in solving swing equation using Range – Kutta method for transient analysis. (10 Marks)
- 8 a. Describe in detail, giving a flow chart, the transient stability algorithm, using modified Euler method. (10 Marks)
- b. What are the network performance equations? Explain how $[Y_{BUS}]$ is modified to include machine and load models for the network solution. (10 Marks)

* * * * *